

Cylinder Controller

SC Series

Flow Control Valve / In-Line Type

SC320	IN-Line Type Port Size Rc $\frac{1}{4}$
SC330	IN-Line Type Port Size Rc $\frac{3}{8}$
SC340	IN-Line Type Port Size Rc $\frac{1}{2}$

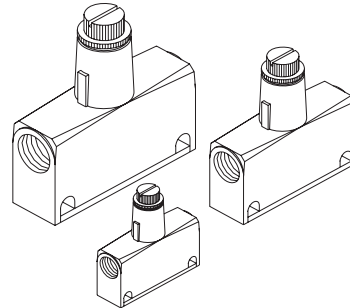

Symbol



Specification

Series		Unit	SC320-08	SC330-10	SC340-15
Port Size		Rc(PT)	$\frac{1}{4}$	$\frac{3}{8}$	$\frac{1}{2}$
Free Flow	Air Flow	ℓ /min	340	800	1650
	Effective Area	mm ²	5	12	24
Controlled Flow	Air Flow	ℓ /min	250	800	1650
	Effective Area	mm ²	3.7	12	24
Fluid			Air		
Using Pressure Range			0.5~0.9		
Temperature Range		°C	0~60		
Weight		g	115	125	240

Dimension

(Unit : mm)

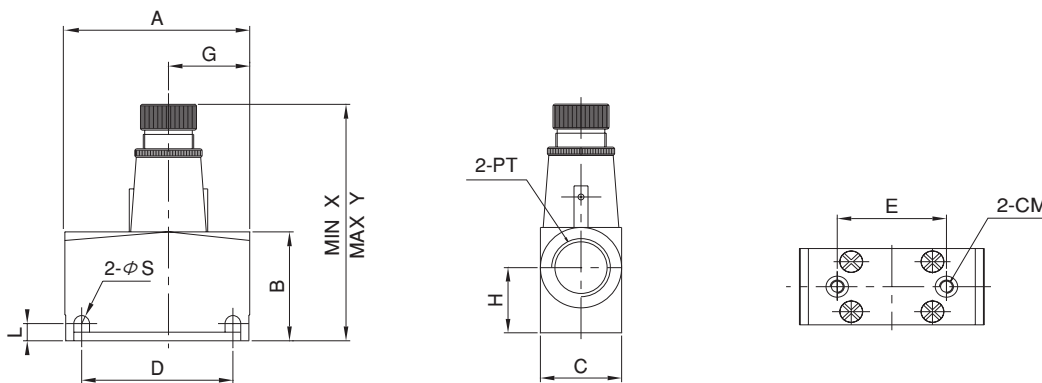

Series	A	B	C	D	E	G	H	L	PT	φS	X	Y	CM
SC320-08	40	27	18	31	31	18	18	5	1/4	4.6	52	56	M3X0.5P dp6
SC330-10	56	33	24	45	32	25	21	5.5	3/8	5.6	63.5	69	M4X0.7P dp9
SC340-15	66	38	29	54	39	29	24	6	1/2	5.6	79	87	M5X0.8P dp8